

Figaro Oxygen Sensor SK-25F

Features:

- * Virtually no influence from CO₂, CO, H₂S, NO, H₂
- * Temperature compensation circuit included
- * Good linearity
- * No position dependency
- * Stable output signal
- * No external power supply required for sensor operation
- * No warmup time is required

Applications:

- * Safety - Air conditioners, oxygen detectors, fire detectors, fuel cell systems
- * Measurement - Oxygen monitors in flue gas
- * Biotechnology - Oxygen incubators, anaerobic cultivators
- * Food industry - Refrigeration, greenhouses

The Figaro Oxygen Sensor SK-25F is a unique galvanic cell type oxygen sensor. Its most notable features are no influence from CO₂, good linearity up to 30% oxygen, and excellent chemical durability. This feature makes the sensor ideal for oxygen monitoring in various applications such as the biochemical field, food industry, and domestic safety applications.



Sensitivity characteristics (typical values under std. test conditions)

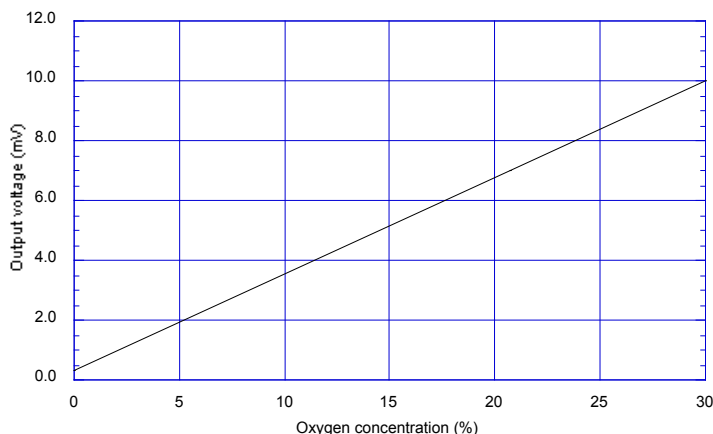

Response time (typical)

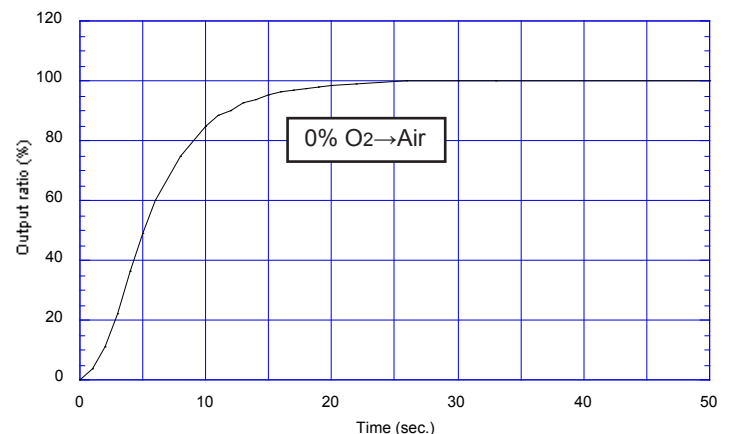

Dimensions

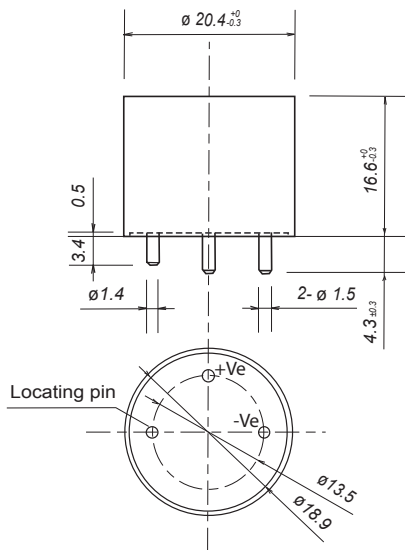

u/m: mm
 If not specified, all tolerances are ± 0.2 mm

Specifications

Item		Model
		SK-25F
Measurement range		0~30% O ₂
Accuracy (Note 1)		$\pm 1\%$ full scale
Operating conditions	Atmospheric pressure	1013hPa $\pm 20\%$
	Temperature	-10 $^{\circ}$ ~50 $^{\circ}$ C
	Relative humidity	0~99%RH (no condensation)
Response time (90%) (Note 2)		≤ 15 seconds
Initial output voltage under factory test conditions		5.5~8.5mV
Factory test conditions	Atmospheric pressure	1013hPa
	Temperature	25 $^{\circ}$ $\pm 5^{\circ}$ C
Life expectancy at 20 $^{\circ}$ C in normal air (Note 3)		approx. 3 years

Notes:

- 1) When calibrated at both 0% and 30% of O₂, accuracy in the range from 0-30% O₂ shall be within $\pm 1\%$ full scale.
- 2) Sensors should be used under conditions where the air exchange is greater than 200~300ml/minute in order to obtain the response speed as specified in Table 1.
- 3) Life expectancy at 20 $^{\circ}$ C in normal air (1013hPa / 20.7% O₂) is defined as the period until sensor output drops to 60% of original value.

NOTE: When the sensor is shipped, blue tape covers the gas diffusion holes to minimize consumption of the sensor life during storage. Before measuring sensor output, the tape should be removed.

